

SERVICE MANUAL

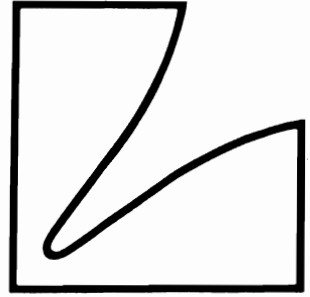

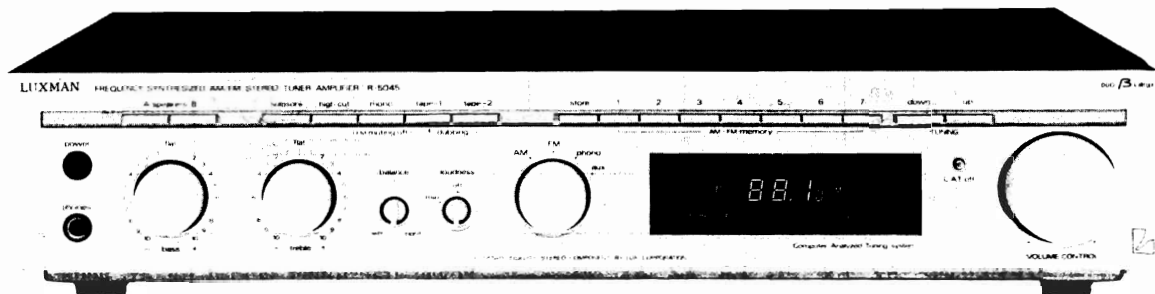



FREQUENCY SYNTHESIZED AM/FM TUNER-AMPLIFIER **R-5045**



CONTENTS

SWITCHES & CONTROLS	1
ALIGNMENT PROCEDURES	2
SEP-UP UNIT	3
BLOCK DIAGRAM	5
TC4016P (TC5027) -Quad Bilateral Switch	6
μ PB533AC (TC5033)-Prescaler	6
μ PD1703C (TC0194)-PLL Synthesigen and Control	7
REPLACEMENT PARTS	8
Parts List Cosmetic, Switch, other	9
P.C.B. parts list	10
R-5045 AUDIO SECTION	19
R-5045 RF, EQ SECTION	20
Specification	21

NOTE: In this service manual the parts which differ depending on destination are described by each symbol indicating its version in the under-mentioned table.

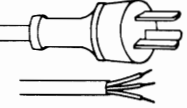
VERSION	SAFETY REGULATION	RADIATION	AC MAINS VOLTAGE	MAINS PLUG	REGION
J	Denki Yoohin Torishimari Hoo	Denki Yoohin Torishimari Hoo	100 V		Japan
Z	UC UZ	CSA LA (UL)	120 V		Canada USA
C	EZ AZ	FCC			North America, Asia South America
K	EK SK AK	SEMKO DEMKO NEMKO	220 V		Europe, Asia South America
D	SD	(SEMKO) (DEMKO) (NEMKO)	220 V		West Germany (Europe)
G	EG SG AG	(BS) (SAA)	240 V		England Oceania
B	EB SB	(SAA)	240 V		Australia
F	Other				

VERSION: EZ, EK, EG, EB, AZ, AK, AG ----- Power transformer tapped for AC main 100V, 120V, 220V, 240V.

UP, UQ ----- Basically these are of "U" (120V) version and following are the difference:

UP: CSA non-approved & LAC's warranty card included.

UQ: CSA approved & LAC's warranty card included.

SL ----- Basically same as "SK" Version.

SWITCHES & CONTROLS

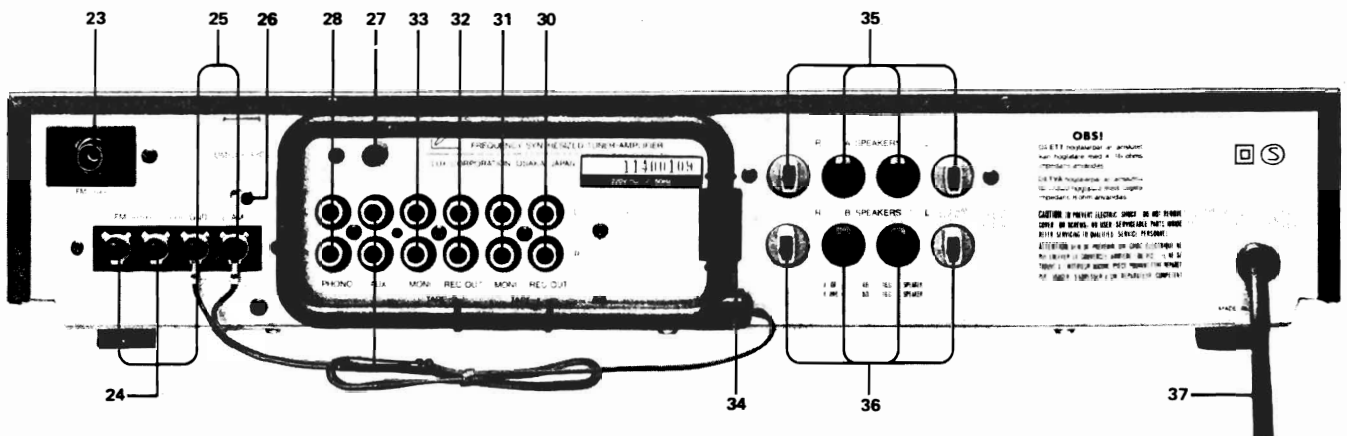
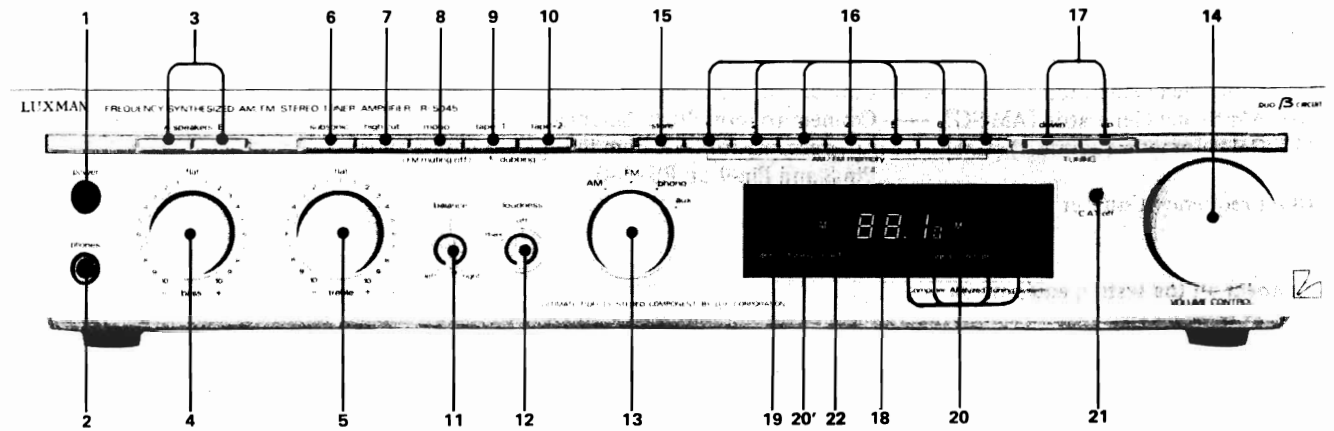

- | | | |
|-------------------------------------|---|-------------------------------------|
| 1. Power Switch | 15. Store Switch | 26. Battery Compartment |
| 2. Head phone Jack | 16. Preset Station Buttons | 27. GND Terminal |
| 3. Speaker Selector Button | 17. Tuning Keys | 28. PHONO Terminal |
| 4. Bass Control | 18. Digital Frequency Readout | 29. AUX Terminal |
| 5. Treble Control | 19. Stereo Indicator | 30. REC. OUT-1 Terminal |
| 6. Subsonic Filter | 20. Signal Strength Indicator | 31. Monitor-1 Terminal |
| 7. High Cut Filter | 21. C.A.T. Off Switch | 32. REC. OUT-2 Terminal |
| 8. Mono/Muting Off Switch | 22. C.A.T. Indicator | 33. Monitor-2 Terminal |
| 9. 10. Tape Monitor/Dubbing Buttons | 23. Coaxial Antenna Connector | 34. AM Loop Antenna Holder |
| 11. Balance Control | 24. FM. Antenna Terminals
(75 ohm and 300 ohm) | 35. 36. Speaker Terminals (A and B) |
| 12. Loudness Control | 25. AM Antenna Terminal | 37. AC Power Cord |
| 13. Input Selector Switch | | |
| 14. Volume Control | | |

ALIGNMENT PROCEDURES

TEST EQUIPMENT REQUIRED AND CONNECTION METHOD.

- (1) Oscilloscope
- (2) AC Voltage meter
- (3) Distortion Analyzer
- (4) FM Signal Generator [FM-SG] — Connect to Antenna terminal through matching network.
- (5) Multi Plex Generator — Connect to [FM-SG]
- (6) AM Signal Generator [AM-SG] — Connect to loop Stick Antenna.
- (7) Galvanometer ($\pm 100\mu A$) [GM] — Connect resistor $33K\Omega$ in series to pin terminal Pin-8 and Pin-9 on PB1380.
- (8) Frequency Counter

Connect all the testing equipments

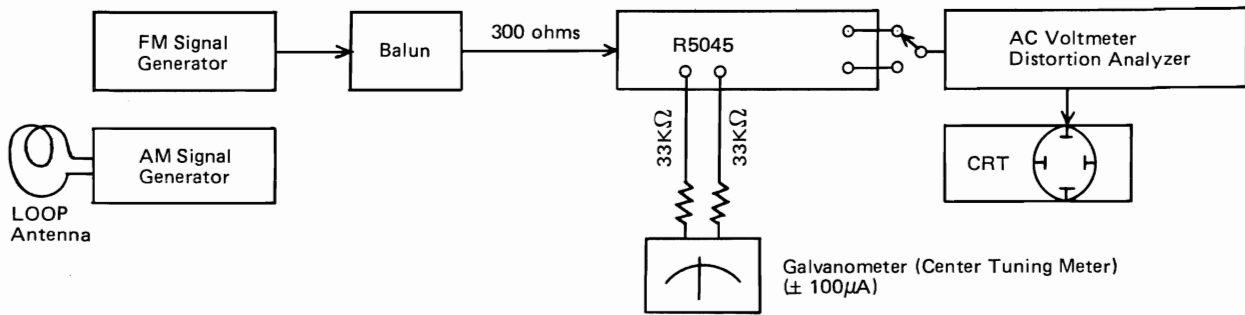

ADJUSTMENT POINT ON PB1380

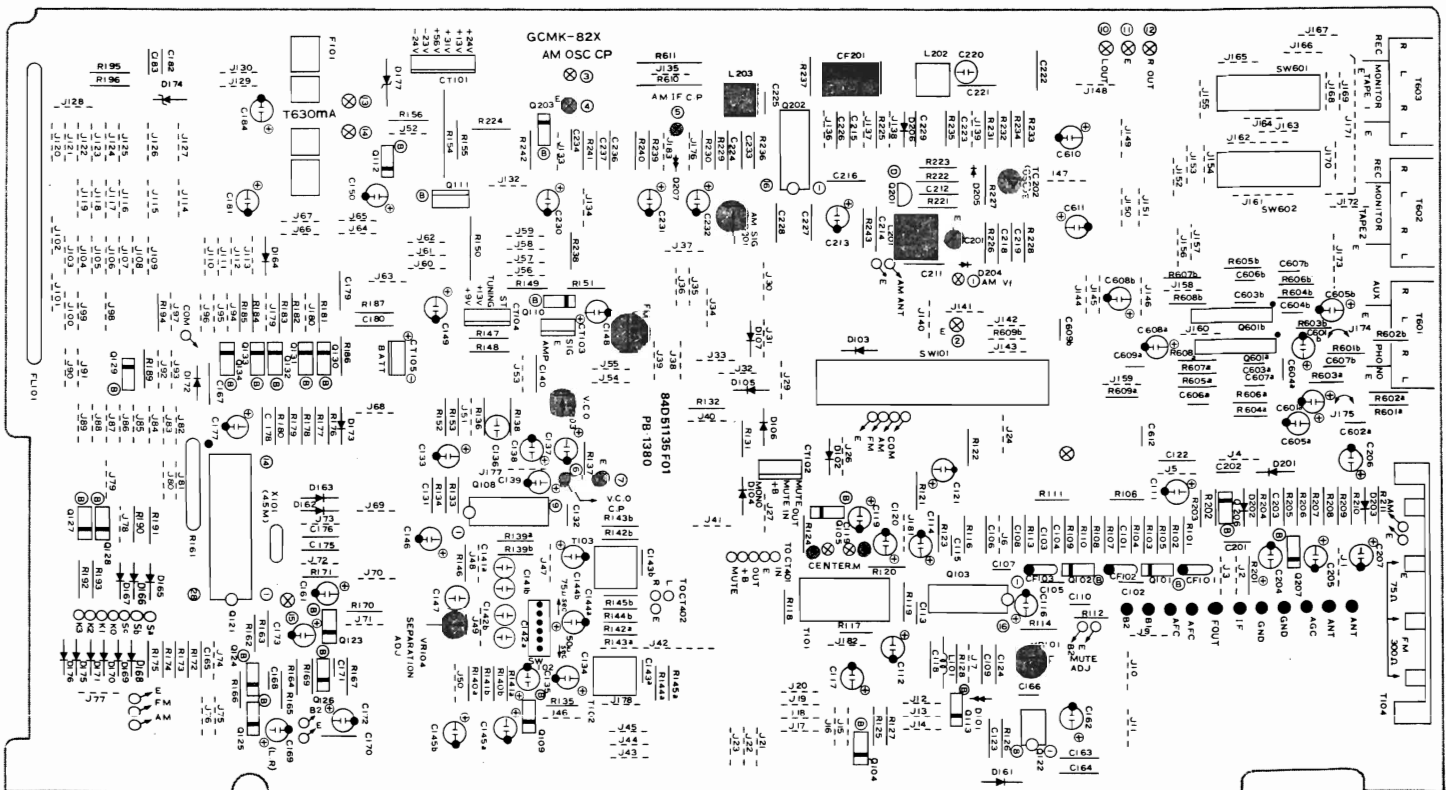

SEP-UP UNIT

PD-1380 PRELIMINARY ADJUSTMENT

- (1) VR-101: Turn to the center position for FM MUTING.
- (2) VR-102: Turn clockwise to the maximum for FM SIGNAL STRENGTH LEVEL.
- (3) VR-103: Turn to the center position for MPX VCO adjustment.
- (4) VR-104: Turn to the center position for MPX SEPARATION adjustment.
- (5) VR-201: Turn counter-clockwise to the maximum for AM SIGNAL STRENGTH LEVEL

Setting of Front panel Switches

- (1) MUTING OFF & MONO: Pushed
- (2) FUNCTION: FM
- (3) C.A.T.: Pushed
- (4) Hi-Cut: Extruded
- (5) Subsonic: Extruded
- (6) TAPE-1/TAPE-2: Extruded

Setting of Front Panel Variable resistor

- (1) VOLUME: Turn to the minimum.
- (2) LOUDNESS: Turn to the minimum.
- (3) TONE CONTROL: Set at the center position
- (4) BALANCE: Set at the center position
- (5) Employ the loop antenna (black) for AM adjustment

AUDIO SECTION

1. Set up unit

- (1) Volume contorol Minimum
- (2) Tone Contorol Flat position
- (3) Speaker A Position

2. Turn on the power switch and await 3 minutes for warming-up.

3. DC offsets adjustment

- (1) Connect DC voltmeter to A speaker terminal.
- (2) Adjust on PB-1379

VR-803a	Left channel
VR-803b	Right channel

 to get 0 V by DC voltmeter.

4. Bias (Idle current) adjustment

- (1) Take off fuse F801a/left chn., F-801b/right chn. on PB-1379.
- (2) Connect DC Ammeter (100-150mA) between the both ends of the fuse holder.
- (3) Adjust on PB-1379

VR-804a	Left channel
VR-804b	Right channel

 to get 50mA by DC Ammeter.

TUNER SECTION

Remarks: It is recommended to adjust AM first since FM SIGNAL ADJUSTMENT is required again when VR-201 is set to the maximum or minimum.

AM

Set the FUNCTION SW at AM.

1. TRACKING ADJUSTMENT

- 1-1 Store 522, 603, 1008, 1404, 1611 KHz by any of 7 memory switches.
- 1-2 Connect Digital Multi Meter to pins No. 1 (hot side) and 2 (cold side) on PD-1380.
- 1-3 Adjust L-202 and TC-202 to obtain $2.0 \pm 0.05V$ and $7.0 \pm 0.05V$ at 603KHz and 1404KHz respectively. Repeat adjustment several times to get above voltages completely.
- 1-4 Confirm that the frequency band from 522 to 1611 KHz can be received by depressing the tuning (up/down) key continuously.
- 1-5 Connect the output of Sweep Generator to AM ANTENNA terminal and set the receiving display at 522 KHz.
- 1-6 Connect the input of Sweep Generator to pin No. 5 (hot side) and 4 (cold side) on PB-1380.
- 1-7 Adjust CF-201 and L-203 so that the IF wave-form should show the maximum and flat signale peak at 450 KHz. In this case, set the output of Sweep Generator at 20-40 dB and obtain the maximum output level without AGC effect by monitoring the wave-form.

- 1-8 Set AM SG at 1404 KHz, 400Hz 30% modulation, and adjust TC-201 to obtain the maximum output level at 50 ~ 55dB/M.
- 1-9 Set the AM SG at 603 KHz and adjust L-201 to procure the maximum output level.
- 1-10 Repeat steps 1-8 & 1-9 one after another until the optimum results can be obtained.
- 2. SIGNAL ADJUSTMENT
- 2-1 Set AM SG at 1008 KHz, with output 80dB/M.
- 2-2 Tune the R5045 at 1008 KHz and adjust VR-201 to make 5 SIGNAL LED's light up.

FM

- 1. CENTER ADJUSTMENT of FM detector.
- 1-1 Set the FM SG at 98.0 MHz, 1MV, nonmodulation.
- 1-2 Tune the R5045 at 98.0 MHz with the display
- 1-3 Connect the center meter to pins No. 8 & 9 on PB1380 and adjust the core T101 [A] at the side of the frontend so that the needle of center meter shows "0".
- 2. TRACKING ADJUSTMENT
- 2-1 Set the FM SG at 108 MHz, about 1 μ V, mono, 100% modulation.
- 2-2 Tune the R5045 at 108 MHz.
- 2-3 Adjust 3 trimmers except for the local oscillator FE-101 (FRONT END) to obtain the maximum output level.
- 2-4 Set the FM SG at 98.0 MHz.
- 2-5 Tune the R5045 at 98.0 MHz and adjust the IFT core of FE-101 (FRONT END) so that the maximum output is obtained.
- 2-6 Push the tuning keys (UP & DOWN) continuously and confirm that the frequency range from 87.50 to 108.00 MHz can be received.
- 3. MUTING LEVEL ADJUSTMENT
- 3-1 Set MUTING OFF & MONO switch extruded.
- 3-2 Set FM SG at 3 μ V.
- 3-3 Adjust VR-101 so that the signal can perfectly come out.
- 4. SIGNAL STRENGTH ADJUSTMENT
- 4-1 Set FM SG at 1MV.
- 4-2 Adjust VR-102 to make 5 LED's light up.
- 4-3 Make output of SG null (0), and confirm no LED illuminates.
- 5. MONO THD ADJUSTMENT
- 5-1 Set FM SG at 1MV.
- 5-2 Adjust the core of T-101 [B] near MPX IC to obtain the minimum distortion.
- 5-3 Since the center meter deviates by 5-2 adjustment, repeat the steps 1-3 & 5-2 until the minimum distortion can be obtained and the center meter shows (0) point. At this time, confirm that the LED, for C.A.T. does not light. When it lights up erroneously, tune out and make tuning again.
- 6. STEREO (DISTORTION, SEPARATION) ADJUSTMENT
- 6-1 Connect Frequency Counter to pins No. 6 (hot side) & 7 (cold side) on PB-1380.
- 6-2 Adjust VR-103 so that the counter indicates within 19 KHz ± 10 Hz when receiving NON MODULATION signal from FM SG.
- 6-3 Set FM SG at 1MV, mixed signals "pilot 10% and 1 KHz, L+R 90%".
- 6-4 If stereo distortion does not meet specification, turn the IFT of EF-101 (FRONT END) within 1/2 turn and set it at such point so that the minimum distortion can be obtained.
- 6-5 As the output at Front-end is lowered by 6-4 adjustment, make re-alignment repeating the steps 3 (Muting level Adj.) and 4 (Signal Strength adj.).
- 6-6 Adjust VR-104 to obtain the well-balanced separation.
- 7. CONFIRMATION FOR C.A.T. FUNCTION
- 7-1 Confirm that CAT LED is turned off when CAT switch is depressed. (CAT OFF). Also confirm that when the CAT Switch is set 'on', the LED is put off at interstation reception. while lighting up when the input signal exceeding muting level is received.
- 7-2 Set FM SG at 1MV, and make the CAT switch extruded (CAT AUTO). Confirm at this time if the CAT LED lights up at once, and that separation is better than 46dB at 1KHz (ANTI-BIRDIE OFF). If impossible to get this figure, after tuning out, make tuning again to get separation exceeding 46dB. Lower the SG output gradually, and confirm that when the SIGNAL LED is shifted from 2 points to one, the separation suddenly comes down to less than 10dB. (CAT AUTO: HIGH-BLEND ON, ANTI-BIRDIE FILTER OFF).
- 7-3 Prepare 2 set of FM SG and RF Mixing Pad, and set the main SG only for PILOT modulated with output at 1MV at ANTENNA terminal, while set the sub SG 100% modulated MONO, 1KHz, setting the frequency by 180 KHz away from that of the main SG, with 500 μ V at ANTENNA. Receive the signal of the main SG and confirm that the audible beat noise level coming from speaker varies by pressing CAT SW on and off alternately.

BLOCK DIAGRAM

R-5045 C.A.T. BLOCK DIAGRAM

C.A.T. (Computer Analyzed Tuning) System

Our innovative C.A.T. system always provides an optimum reception according to the ambient conditions. Specifically, the anti-birdie and high-blend circuits are automatically activated, depending on the necessity, by sensing the electric field strength and interference by other stations, etc. The anti-birdie filter is useful to remove so-called "birdie" noises triggered by interference of FM stations adjacent to the desired one especially in central Europe having high congestion of stations.

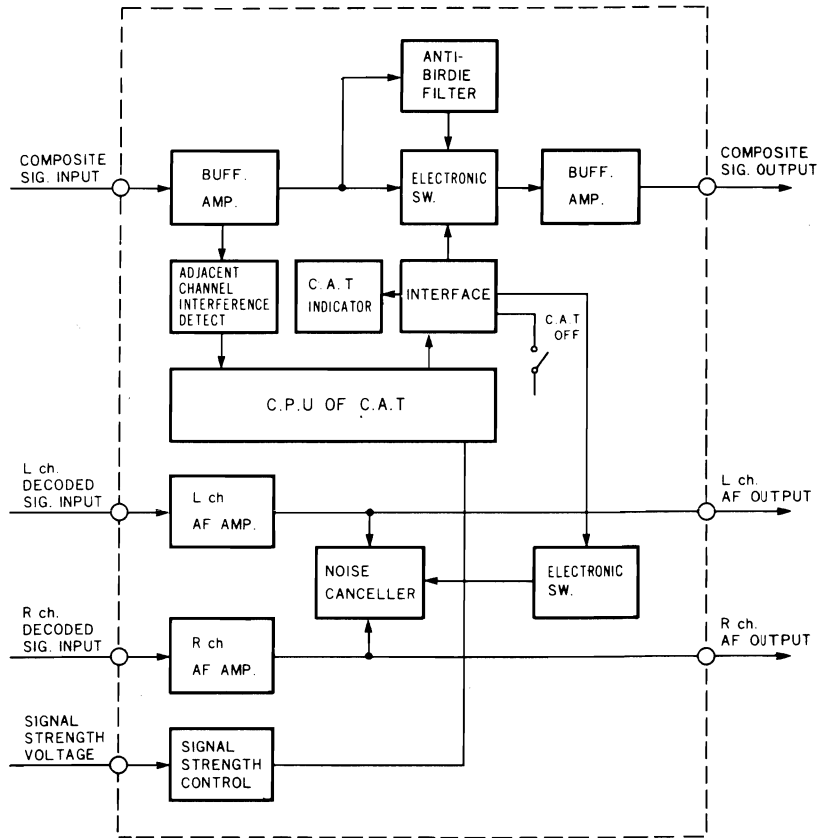

STK3042 (TC0192)

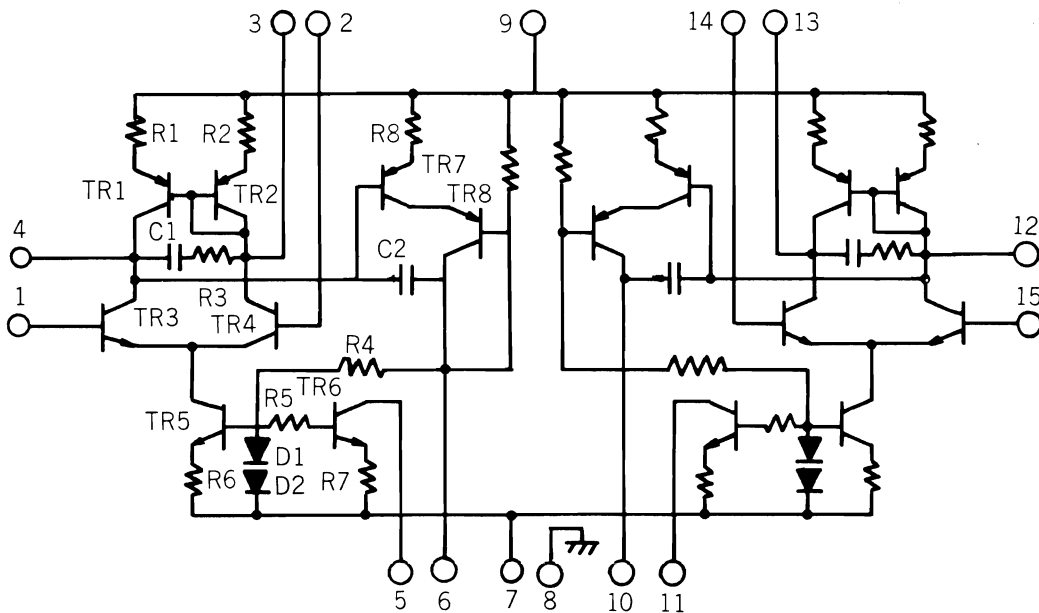

TC4016 (TC5027) -Quad Bilateral Switch

Truth table

CONT	IN	OUT
H	$V_{DD} \sim GND$	V_{IN}
L	$V_{DD} \sim GND$	—

Pin Connection

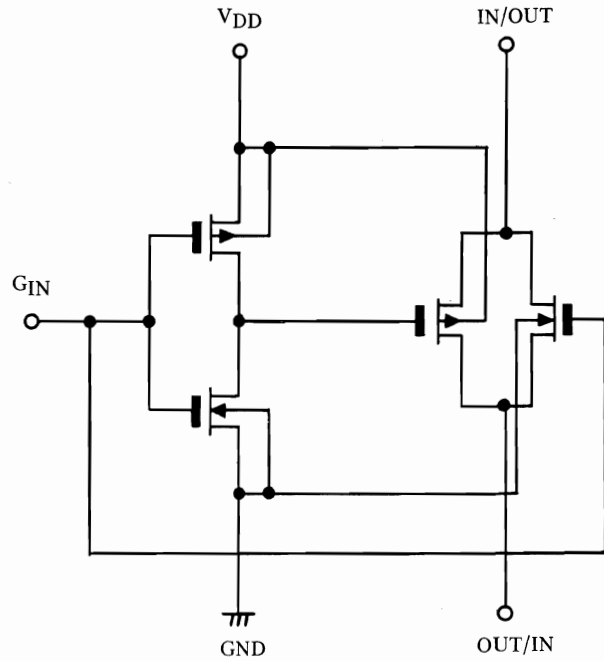
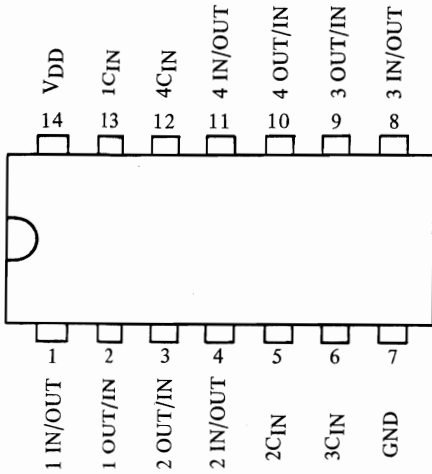

uPB533AC (TC5033)-Prescaler

BLOCK DIAGRAM

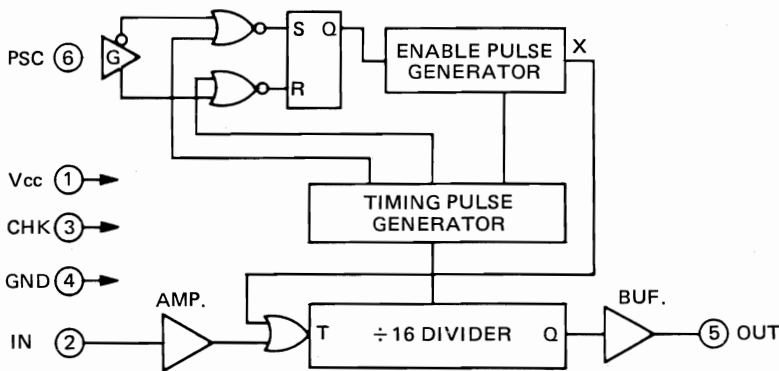

PIN CONNECTION

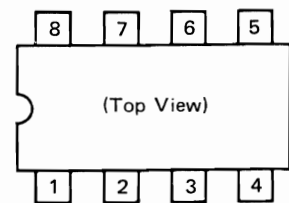

Pin No.	Function
1	Vcc
2	IN
3	CHK
4	GND
5	OUT
6	PSC
7	NC
8	NC

TIMING CHART

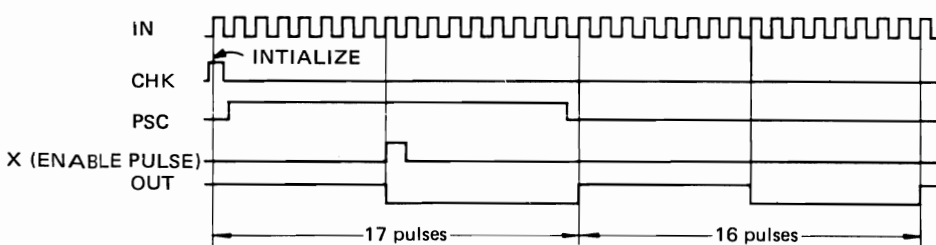

uPD1703C (TC0194)-PLL Synthesigen and Control

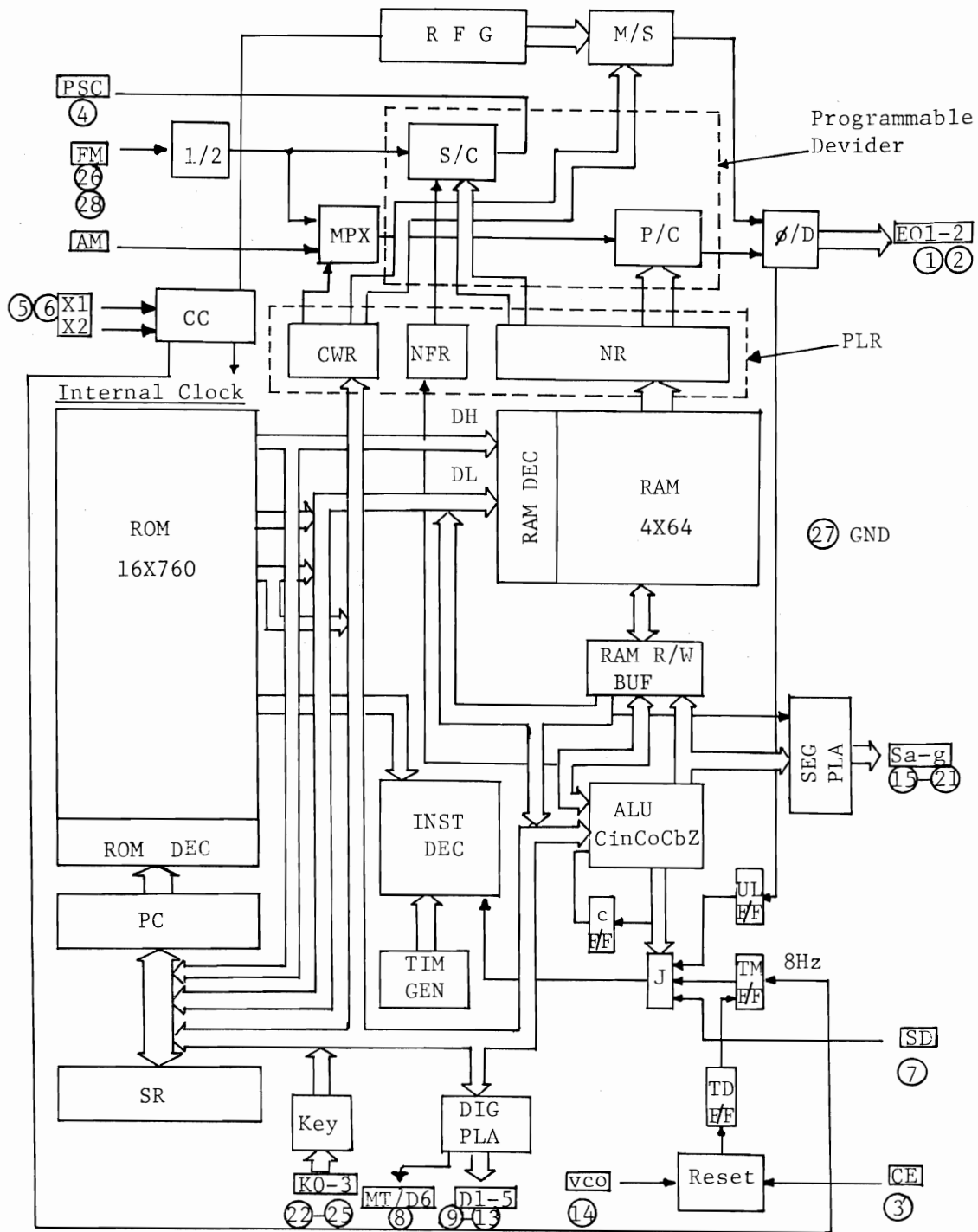

REPLACEMENT PARTS

Front View

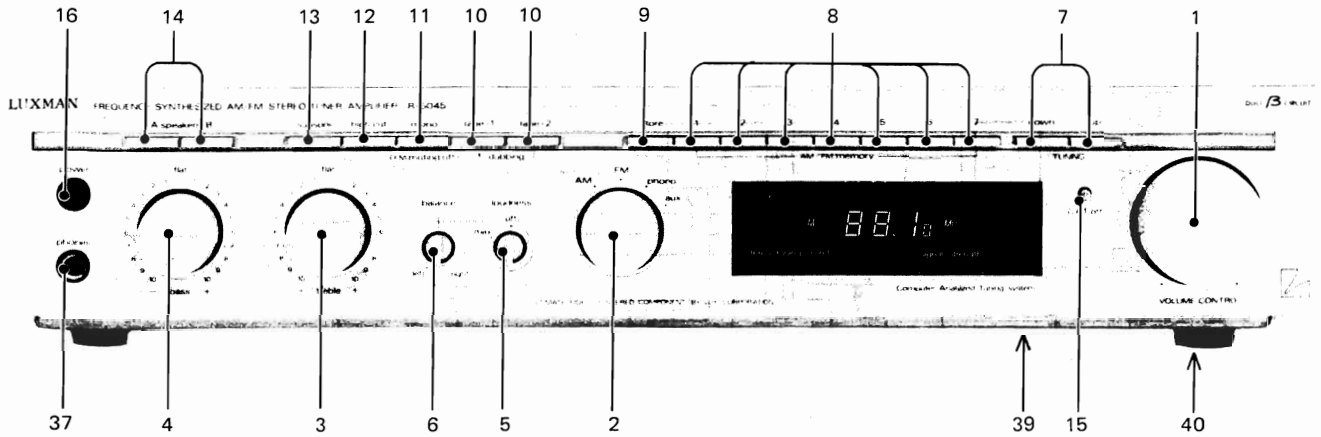

Rear View

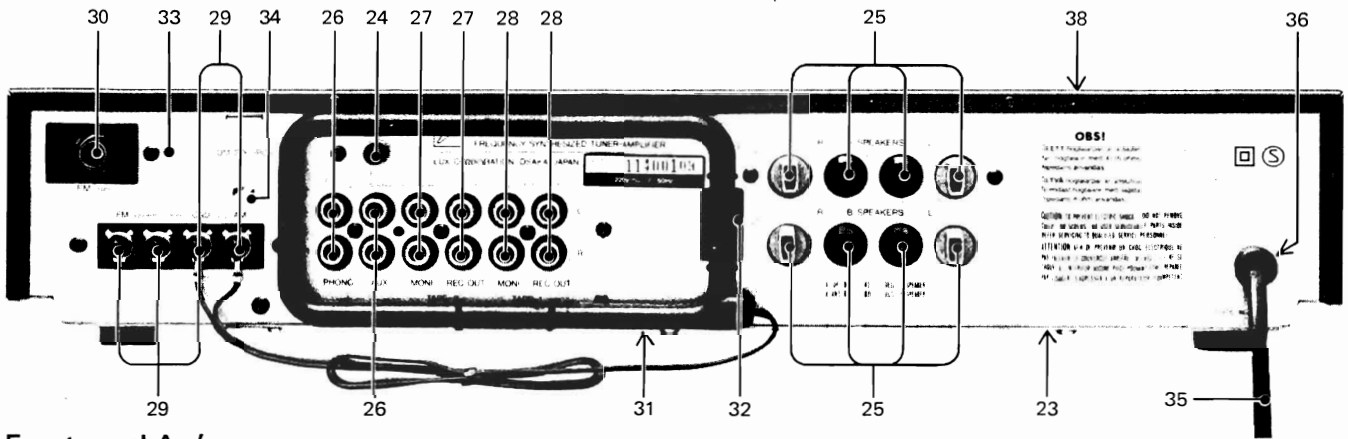

Front panel Ass'y

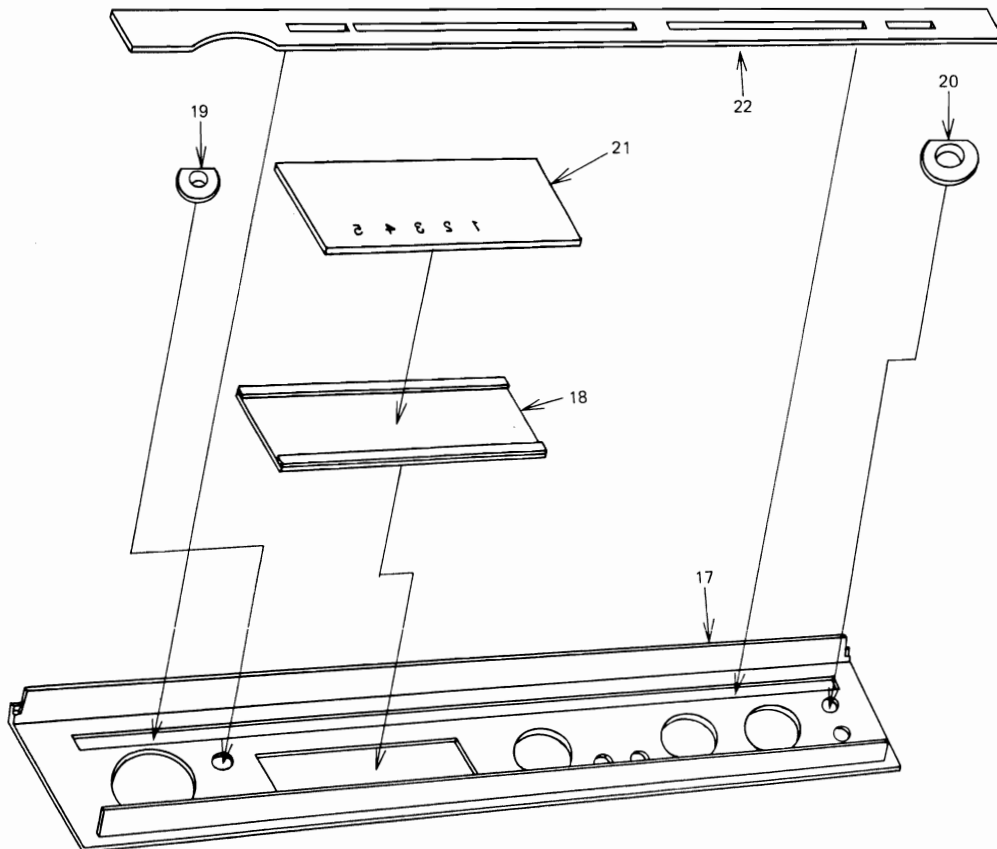

Parts ListCosmetic, Switch, other

SYMBOL NO.	STOCK NO.	DESCRIPTION	REMARK	SYMBOL NO.	STOCK NO.	DESCRIPTION	REMARK
[Knob]				[Line voltage selector] · · · · · E only			
1	36R51142F01-0	Volume cont.			AC0054	Socket	
2	36R51143F01-0	Function			AC0041	Plug	
3	36R51143F01-0	Treble			15A51044F01-0	Cover, plug	
4	36R51143F01-0	Bass		[Switch]			
5	36B51053F01-A	Loudness		SW509.10	40T51081F01-0	Up, Down	
6	36B51053F01-A	Balance		SW501-8	40T51081F01-0	Memory, Store	
7	36B51051F01-A	Up, Down		SW601-2	40T51099F01-0	Tape-1, 2	
8	36B51052F01-A	Memory		SW703	40T51113F01-0	Mono	
9	36B51052F01-A	Store		SW702	40T51113F01-0	High cut	
10	36B51051F01-A	Tape-1, 2		SW701	40T51113F01-0	Subsonic	
11	36B51051F01-A	Mono		SW704	40T51113F01-0	Speaker	
12	36B51051F01-A	High cut		SW401	40T51082F01-B	CAT	
13	36B51051F01-A	Subsonic		SW001	SP0167	Power	
14	36B51051F01-A	Speaker			SP0166	Power	U only
15	36R43798U02-A	CAT		SW101	40T51097F01-0	Function, slid	
16	36R51144F01-0	Power		[Potentiometer]			
[Front Panel]				VR901	18T5110F01-0	Volume cont. 100K x 2 B	
17	64D51137F01-B	Front panel		VR801	18T51109F01-0	Loudness	
18	61A51035F01-0	Protector		VR802	18T51111F01-0	Balance	
19	07R51141F01-0	Protector		VR806	18T51112F01-0	Treble	
20	07R47364F01-0	Protector		VR805	18T51112F01-0	Bass	
21	61A51045F01-A	Filter		[Other]			
22	07D51064F01-0	Escutcheon		37	AT0020	Head Phone jack	
[Rear Panel]				38	15D51063F01-A	Bonnet	
23	15D51060F01-D	Rear panel	SD	39	15D51062F01-A	Bottom plate	
	15D51060F02-B		SG, SK	40	75A43532P01-A	Foot	
	15D51060F03-B		E		45C51054F01-B	Extension arm, Tape sel.	
24	AG0120	GND terminal			45B51050F01-A	CAT	
25	09T51101F01-0	Speaker terminal			25T52990F01-0	Power transformer	U
26	09T51123F01-0	Input terminal Aux Phono				120V	S
27	09T51123F01-0	Tape-2			25T51073F01-0	220, 240V	E
28	09T51123F01-0	Tape-1			25T51829F01-0	100-240V	
29	09T51122F01-0	ANT. terminal, 4p			TR0329	Power Tr, 2SA1102	
30	AS0156	75 ohm	SG, SK		TR0330	Power Tr, 2SC2577	
	AS0046	75 ohm	SD		TR0198	Bias Tr, 2SC1815	
31	85T51078F01-0	Loop ANT.		[Packing material]			
32	55T51079F01-0	Loop ANT. holder			56C50570F07-0	Carton	
	09T51065F01-0	Battery holder			56D51147F01-0	Pad	
	09T51068F01-0	Battery case			68R51239F01-A	Owner's manual	
33	15A51043F01-A	Battery cover					
34	03AD51797F01	Screw, Battery cover					
35	BK0018	Power Cord	EZ				
	BK0022		EK, SK, SD				
	BK0023		SG				
36	BU0033	Bushing					
	09T51832F01-0	AC Outlet	E only				

P.C.B. parts list

REMARKS

Capacitor:	My Mylar,	El Electrolytic,	St Styrol,	Ce Ceramic
	Mi Mica,	Ta Tantalum,	Lp Line pass (AC Cap.)	
	Tm Trimmer	Ac Ac Capacitor,	Fi Film Cap	
Resistor:	Rd Carbon,	Rc Cement,	Rm Metal Film,	Rf Flame proof
	Ro Oxid Metal,			
	± 5%, 0.25W, unless specified otherwise.			

PB-1377

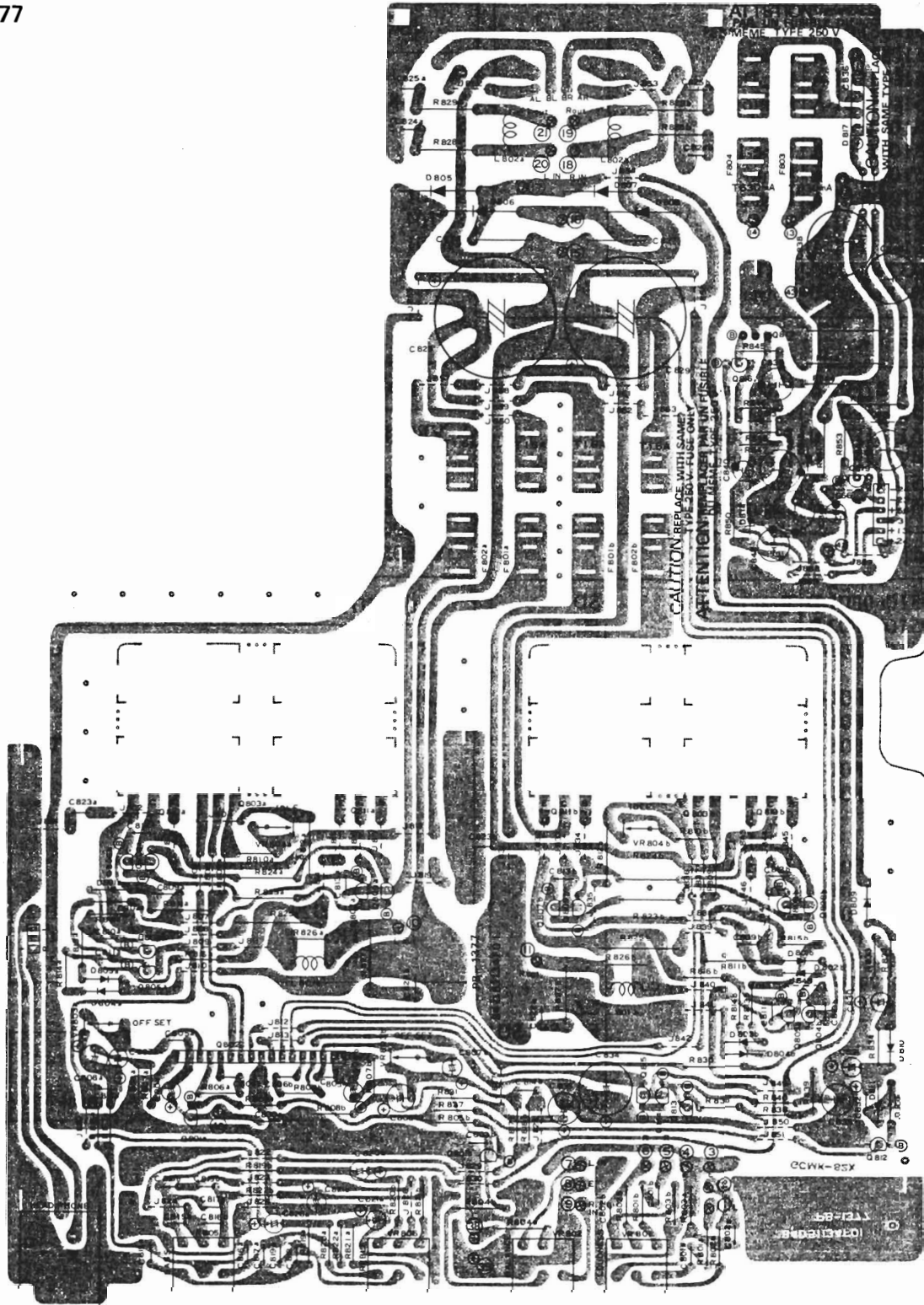

SYMBOL NO.	STOCK NO.	DESCRIPTION	REMARK
[Capacitor]			
C701A, B	CQ0178T	0.12μ 50V My	
C702A, B	CQ0018T	0.0056μ 50V My	
C801A, B	CQ0028T	0.0018μ 50V My	
C802A, B	CQ0011T	0.033μ 50V My	
C803A, B	CC00071	100P 50V Ce	SD
	CC0009T	200P 50V Ce	
C804A, B	CE0785		
C805A, B	CC0035T	270P 50V Ce	SD
	CC0011T	470P 50V Ce	
C806A, B	CC0008T	150P 50V Ce	
C807A, B	CE1750T	1μ 50V El	
C808A, B	CE1720T	47μ 16V El	
C809A, B	CK0146T	0.04μ 50V Ce	
C810A, B	CC0011T	470P 50V Ce	
C811A, B	CC0011T	470P 50V Ce	
C812A, B	CC0161T	56P 50V Ce	
C813A, B	CC0005T	33P 50V Ce	
C814A, B	CM0052	15P 500V Mi	
C815A, B	CQ0027T	0.0068P 50V My	
C816A, B	CQ0011T	0.033μ 50V My	
C817A, B	CQ0007T	0.068μ 50V My	
C818A, B	CQ0020T	0.0039μ 50V My	
C819A, B	CQ0013T	0.022μ 50V My	
C820A, B	CE1753T	4.7μ 50V El	
C821A, B	CE1718T	22μ 50V El	
C822A, B	CQ0009T	0.047μ 50V My	
C823A, B	CK0146T	0.04μ 50V Ce	SD
C824A, B	CK0146T	0.04μ 50V Ce	SD
C825A, B	CK0146T	0.04μ 50V Ce	SD
C826	CU0040	0.01μ 25V Ac	
C827	CU0040	0.01μ 25V Ac	
C828	CE1027	6,800μ 50V El	
C829	CE1027	6,800μ 50V El	
C830	CE1754T	10μ 50V El	
C831	CE1754T	10μ 50V El	
C832	CK0155T	0.01μ 50V Ce	
C833	CE1753T	4.7μ 50V El	
C834	CE1759	220μ 50V El	
C835	CE1757T	47μ 50V El	
C836	CK0195	0.01μ 500V Ce	
C837	CE1733	220μ 25V El	
C838	CE1747	1000μ 35V El	
C839	CE1721T	100μ 16V El	
C840	CE1710T	47μ 10V El	
C841	CE1722	220μ 16V El	
C842	CE1712T	220μ 10V El	
C843	CE1746	470μ 35V El	
C844	CE1733	220μ 25V El	
C845	CE1729T	22μ 25V El	

SYMBOL NO.	STOCK NO.	DESCRIPTION	REMARK
[Diode]			
D801A, B	TD0227T	1SS41	
D802A, B	TD0227T	1SS41	
D803A, B	TD0227T	1SS41	
D804A, B	TD0227T	1SS41	
D805	TD0105	S3V20	
D806	TD0105	S3V20	
D807	TD0105	S3V20	
D808	TD0105	S3V20	
D809	TD0003	IN4003	
D810	TD0003	IN4003	
D811	TD0177	ZENER WZ-182	
D813	TD0045	ZENER WZ-056	
D812	TD0068T	ZENER WZ-240	
D814	TD0045	ZENER WZ-056	
D815	TD0068T	ZENER WZ-240	
D817	TD0137	S1VB10	
[Transistor, IC]			
Q801A, B	TR0087	2SA1015	
Q802	TC0192	IC, STK-3042	
Q804A, B	TR0198	2SC1815	
Q805A, B	TR0087	2SA1015	
Q806A, B	TR0198	2SC1815	
Q807A, B	TR0087	2SA1015	
Q808A, B	TR0264	2SC2235	
Q809A, B	TR0263	2SA965	
Q812	TR0320	2SA992	
Q813	TR0320	2SA992	
Q814	TR0320	2SA992	
Q815	TR0263	2SA965	
Q816	TR0198	2SA1815	
Q817	TR5012	2SD880	
Q819	TR0087	2SA1015	
[Resistor]			
R701 A, B	RB0444T	1M	
R702A, B	RB0444T	1M	
R703A, B	RB0384T	3.3K	
R704A, B	RB0392T	6.8K	
R705A, B	RS2568L	220	
R801A, B	RB0378T	1.8K	
R802A, B	RB0388T	4.7K	
R803A, B	RB0390T	5.6K	
R804A, B	RD0133	560 1/2	
R805A, B	RB0396T	10K	
R806A, B	RB0374T	1.2K	
R807A, B	RB0414T	56K	

PB-1383

SYMBOL NO.	STOCK NO.	DESCRIPTION	REMARK
R808A, B	RB0364T	470	
R809A, B	RB0392T	6.8K	
R810A, B	RB0376T	1.5K	
R811A, B	RS2506L	33	
R812A, B	RS2506L	33	
R813A, B	RB0400T	15K	
R814A, B	RB0400T	15K	
R815A, B	RB0360T	330	
R816A, B	RB0360T	330	
R817A, B	RB0394T	8.2K	
R818A, B	RB0412T	47K	
R819A, B	RB0394T	8.2K	
R820A, B	RB0378T	1.8K	
R822A, B	RB0376T	1.5K	
R823A, B	RS2528L	2.2K 1/2W Rf	
R824A, B	RS2514L	150 1/2W Rf	
R825A, B	RG0600	0.22 5W Rc	
R826A, B	RB0324T	10	
R827A, B	RS2501L	10 1/2W Rf	
R830	RS2508L	47 1/2W Rf	
R831	RB0422T	120K	
R832	RB0372T	1K	
R833	RB0396T	10K	
R834	RB0432T	330K	
R835	RB0412T	47K	
R836	RB0396T	10K	
R837	RB0396T	10K	
R838	RB0404T	22K	
R839	RB0420T	100K	
R840	RB0372T	1K	
R841	RS2519L	390 1/2W Rf	
R842	RS2954LA	100 2W Rf	
R843	RS2954LA	100 2W Rf	
R844	RB0370T	820	
R845	RB0370T	820	
R846	RB0378T	8.2K	
R847	RB0396T	10K	
R848	RB0396T	10K	
R850	RD0134	470 1/2W	
R852	RS2518L	330 1/2W Rf	
R853	RB0406T	27K	
[Switch]			
SW701	SP0198	SUL531S	
SW702	SP0198	SUL531S	
SW703	SP0198	SUL531S	
SW704	SP0198	SUL531S	
SW705	SP0198	SUL531S	
[Potentiometer]			
VR801	RV0283	100K x 2 (A)	
VR802	RV0285	250K x 2 (MN)	
VR803A, B	RT0056	50K (B)	
VR804A, B	RT0050	500 (B)	
VR805	RV0286	50K x 2 (C)	
VR806	RV0286	50K x 2 (C)	
VR901	RV0284	100K x 2(B)	
R828A, B	RS2501L	10 1/2W	SD
R829A, B	RS2501L	10 1/2W	SD

SYMBOL NO.	STOCK NO.	DESCRIPTION	REMARK
[Switch]			
SW501	SP0261	KHC 15001	
SW502	SP0261	KHC 15001	
SW503	SP0261	KHC 15001	
SW504	SP0261	KHC 15001	
SW505	SP0261	KHC 15001	
SW506	SP0261	KHC 15001	
SW507	SP0261	KHC 15001	
SW508	SP0261	KHC 15001	
SW509	SP0261	KHC 15001	
SW510	SP0261	KHC 15001	

Power, Bias, Transistor

SYMBOL NO.	STOCK NO.	DESCRIPTION	REMARK
[Transistor]			
Q803A	TR0198	TR 2SC1815	Bias
Q803B	TR0198	TR 2SC1815	Bias
Q810A	TR0330	TR 2SC2577	Power
Q810B	TR0330	TR 2SC2577	Power
Q811A	TR0329	TR 2SA1102	Power
Q811B	TR0329	TR 2SA1102	Power

PB-1380

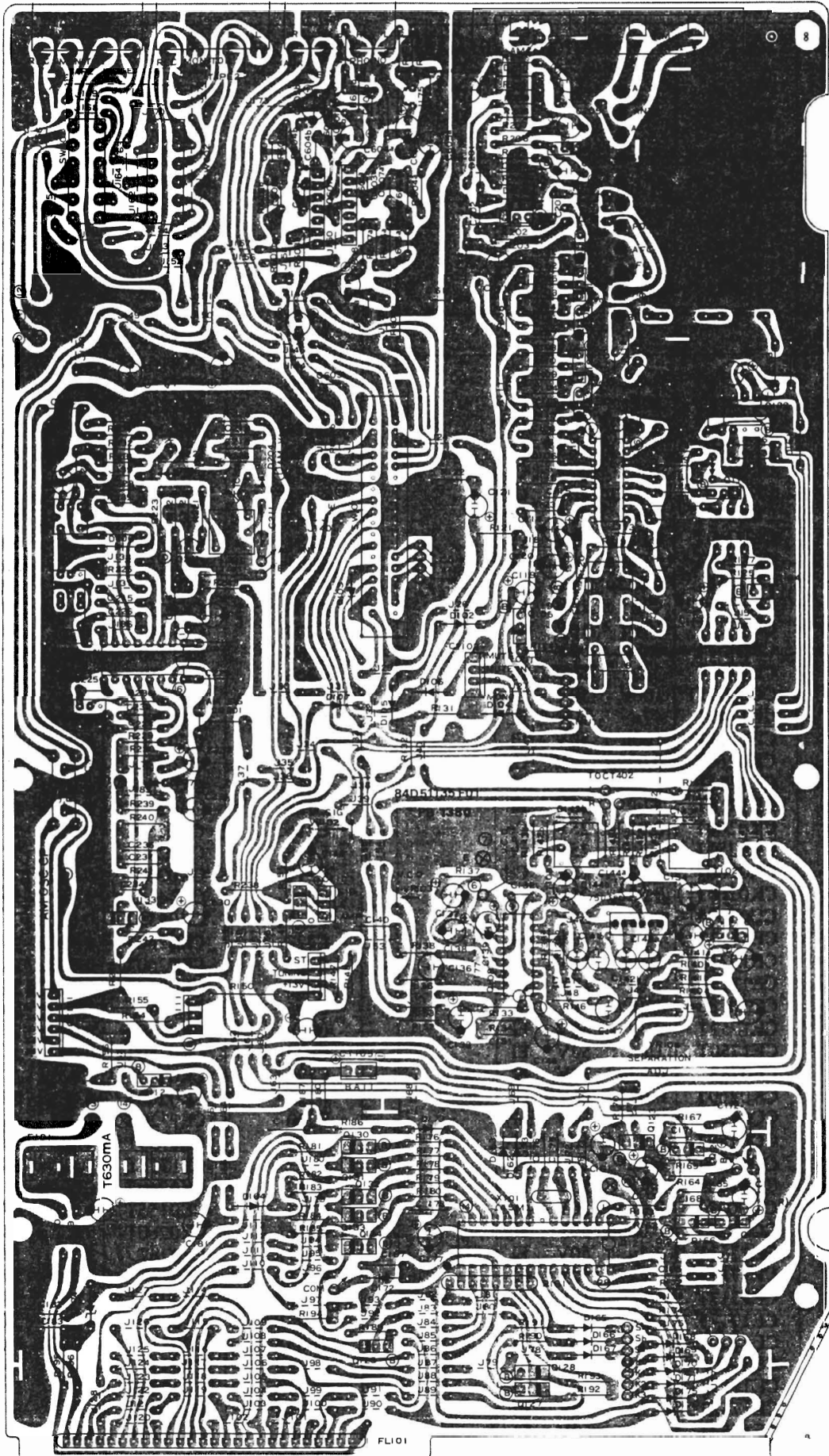

SYMBOL NO.	STOCK NO.	DESCRIPTION	REMARK
J148 J3	CK0142 RB0342T	0.1 μ F 50V Ce 50 ohm	SD SD
[Ceramic filter]			
CF101 CF102 CF103 CF201	LA1840 LA1840 LA1839 LA1455	SEE10.7 (Red) AM48T-067	
[Capacitor]			
C101	CK0260T	0.022 μ 50V Ce	
C102	CC0033T	10P 50V Ce	
C103	CK0260T	0.022 μ 50V Ce	
C104	CK0260T	0.022 μ 50V Ce	
C105	CC0033T	10P 50V Ce	
C106	CK0260T	0.022 μ 50V Ce	
C107	CK0157T	0.04 μ 50V Ce	
C108	CK0260T	0.022 μ 50V Ce	
C109	CK0260T	0.022 μ 50V Ce	
C110	CK0156	0.022 μ 50V Ce	
C111	CE1720T	47 μ 16V Ce	
C112	CE1721T	100 μ 16V El	
C113	CK0157T	0.04 μ 50V Ce	
C114	CE1751T	2.2 μ 50V El	
C115	CC00071T	100P 50V El	
C116	CE1749T	47 μ 50V El	
C117	CE1721T	100 μ 50V El	
C118	CK0260T	0.022 μ 25V Ce	
C120	CE1751T	2.2 μ 50V El	
C121	CE1718T	22 μ 16V El	
C122	CK0260T	0.022 μ 25V Ce	
C123	CK0251T	220P 25V Ce	
C124	CK0260T	0.022 μ 25V Ce	
C131	CK0260T	0.022 μ 25V Ce	
C132	CQ0009T	0.04 μ 25V My	
C133	CE1717T	10 μ 16V El	
C134	CE1721T	100 μ 16V El	
C135	CE1717T	10 μ 16V El	
C136	CQ5078	470P 50V St	
C137	CE1752T	3.3 μ 50V El	
C138	CE1750T	1 μ 50V El	
C139	CE0783	0.22 μ 50V El	
C140	CK0260T	0.022 μ 25V Ce	
C141A	CQ0130T	0.001 μ 50V My	
C141B	CQ0130T	0.001 μ 50V My	
C142A	CQ0304T	680P 50V PP	
C142B	CQ0304T	680P 50V PP	
C143A	CQ0027T	0.0068 μ 50V My	
C143B	CQ0027T	0.0068 μ 50V My	
C144A	CE1751T	2.2 μ 50V El	
C144B	CE1751T	2.2 μ 50V El	
C145A	CE1717T	10 μ 16V El	
C145B	CE1717T	10 μ 16V El	
C146	CE1720T	47 μ 16V El	
C147	CQ1403	100P 50V St	
C148	CE1717T	10 μ 16V El	
C150	CE1753T	4.7 μ 50V El	
C161	CE1753T	4.7 50V El	

SYMBOL NO.	STOCK NO.	DESCRIPTION	REMARK
C162	CE1720T	47 μ 16V El	
C163	CK0260T	0.022 μ 25V Ce	
C164	CK0260T	0.022 μ 25V Ce	
C165	CK0260T	0.022 μ 25V Ce	
C166	CC0033T	10P 50V Ce	
C167	CK0255T	0.001 μ 25V Ce	
C168	CK0156	0.022 μ 25V Ce	
C169	CE0789	4.7 μ 50V El	
C170	CK0260T	0.022 μ 25V Ce	
C171	CK0156	0.022 μ 25V Ce	
C172	CE0787	2.2 μ 50V El	
C173	CE1729T	22 μ 25V El	
C175	CC0161T	56P 50V Ce	
C176	CC0161T	56P 50V Ce	
C177	CE1706	1000 μ 6.3V El	
C178	CK0260T	0.022 μ 25V Ce	
C180	CK0260T	0.022 μ 25V Ce	
C181	CE1733	220 μ 25V El	
C182	CK0156	0.022 μ 25V Ce	
C183	CK0156	0.022 μ 25V Ce	
C184	CE1749T	47 μ 50V El	
C201	CK0155T	0.01 μ 50V Ce	
C202	CC0007T	100P 50V Ce	
C203	CK0255T	0.001 μ 25V Ce	
C204	CE1749T	47 μ 50V El	
C205	CE1750T	1 μ 50V El	
C206	CE1717T	10 μ 16V El	
C207	CE1717T	10 μ 16V El	
C211	CK0260T	0.022 μ 25V Ce	
C212	CK0260T	0.022 μ 25V Ce	
C213	CE1721T	100 μ 16V Ce	
C214	CK0260T	0.022 μ 25V Ce	
C215	CK0260T	0.022 μ 25V Ce	
C216	CK0260T	0.022 μ 25V Ce	
C218	CK0260T	0.022 μ 25V Ce	
C219	CK0260T	0.022 μ 25V Ce	
C220	CQ1412	270P 50V St	
C221	CK0255T	0.001 μ 25V Ce	
C222	CK0260T	0.022 μ 25V Ce	
C223	CK0260T	0.022 μ 25V Ce	
C224	CK0257T	0.0047 μ 25V Ce	
C225	CC0162	180P 50V Ce	
C226	CK0260T	0.022 μ 25V Ce	
C227	CK0260T	0.022 μ 25V Ce	
C228	CK0260T	0.022 μ 25V Ce	
C229	CK0260T	0.022 μ 25V Ce	
C230	CE1720T	47 μ 16V El	
C231	CE1753T	4.7 μ 50V El	
C232	CE1717T	10 μ 16V El	
C233	CK0260T	0.022 μ 25V Ce	
C234	CK0155T	0.01 μ 50V Ce	
C236	CK0260T	0.022 μ 25V Ce	
C601A	CE0787	2.2 μ 50V El	
C601B	CE0787	2.2 μ F 50V El	
C602A	CC0011T	470P 50V Ce	
C602B	CC0011T	470P 50V Ce	
C603A	CK0113T	0.001 μ 50V Ce	
C603B	CK0113T	0.001 μ 50V Ce	
C604A	CC0006T	47P 50V Ce	
C604B	CC0006T	47P 50V Ce	
C605A	CE1720T	47 μ 16V El	

SYMBOL NO.	STOCK NO.	DESCRIPTION	REMARK
C605B	CE1720T	47μ 16V El	
C606A	CQ0015T	0.012μF 50V My	
C606B	CQ0015T	0.012μ 50V My	
C607A	CQ0020T	0.039μ 50V My	
C607B	CQ0020T	0.039μ 50V My	
C608A	CE0786	1μ 50V El	
C608B	CE0786	1μ 50V El	
C609A	CC0007T	100P 50V Ce	
C609B	CC0007T	100P 50V Ce	
C610	CE1733	220μ 25V El	
C611	CE1733	220μ 25V El	
C612	CK0157T	0.04μ 50V Ce	

[Diode]			
D101	TV0030	VARISTOR, KB265C4	
D102	TD0227T	Di. 1SS41	
D103	TD0227T	Di. 1SS41	
D104	TD0227T	Di. 1SS41	
D105	TD0227T	Di. 1SS41	
D106	TD0227T	Di. 1SS41	
D107	TD0227T	Di. 1SS41	
D161	TD0027T	Di. 1SS41	
D162	TD0227T	Di. 1SS41	
D163	TD0227T	Di. 1SS41	
D164	TD0227T	Di. 1SS41	
D165	TD0227T	Di. 1SS41	
D166	TD0227T	Di. 1SS41	
D167	TD0227T	Di. 1SS41	
D168	TD0227T	Di. 1SS41	
D169	TD0227T	Di. 1SS41	
D170	TD0227T	Di. 1SS41	
D172	TD0227T	Di. 1SS41	
D173	TD0227T	Di. 1SS41	
D174	TD0045	ZENER, WZ-056 (5, 6V)	
D175	TD0227T	Di. 1SS41	
D176	TD0227T	Di. 1SS41	
D176	TD0227	Di. 1SS41	
D177	TD0036	ZENER, ZW-260 (26V)	
D201	TD0018	Di. 1K188FM	
D202	TD0018	Di. 1K188FM	
D203	TD0018	Di. 1K188FM	
D204	TD0228	VARACTOR, SVC321	
D205	TD0228	VARACTOR, SVC321	

[Transformer, Coil, other]			
L101	LA1023	Coaxial coil LA104T	
L201	LA1210	Loop ANT.	
L202	LA1456	AM OSC	
L203	LA1458	AM IFT	
FE101	LA1916	Front end, FD216U 11X	
FL101	TT5010	FL. IHDICATOR	

SYMBOL NO.	STOCK NO.	DESCRIPTION	REMARK
[Transistor]			
Q101	TR0353	2SC2063P	
Q102	TR0353	2SC2063P	
Q103	TC0190	LA1235	
Q104	TR0354	2SC2021R	
Q105	TR0354	2SC2021R	
Q108	TC0193	UPC1235C	
Q109	TR0354	2SC2021R	
Q110	TR0354	2SC2021R	
Q111	TR5012	2SD880	
Q112	TR0354	2SC2021R	
Q113	TR0354	2SC2021R	
Q121	TC0194	IC UPD1703C	
Q122	TC5033	UPB553AC	
Q123	TR0354	2SC2021R	
Q124	TR0354	2SC2021R	
Q125	TR0354	2SC2021R	
Q126	TR0355	2SC1545B	
Q127	TR0354	2SC2021R	
Q128	TR0354	2SC2021R	
Q129	TR0354	2SC2021R	
Q130	TR0356	2SA937R	
Q131	TR0356	2SA937R	
Q132	TR0356	2SA937R	
Q133	TR0356	2SA937R	
Q134	TR0356	2SA937R	
Q201	TF0031	FET 2SK61	
Q202	TC0169	IC LA1240	
Q203	TR0354	2SC2021R	
Q204	TR0354	2SC2021R	
Q206	TR0353	2SC2063P	
Q207	TR0354	2SC2021R	
Q601A	TC0195	IC M5213L	
Q601B	TC0195	IC M5213L	

[Resistor]			
R101	RB0364T	470	
R102	RB0382T	2.7K	
R103	RB0348T	100	
R104	RB0348T	100	
R105	RB0360T	330	
R106	RE0348T	100	
R107	RB0364T	470	
R108	RB0382T	2.7K	
R109	RB0364T	470	
R110	RB0360T	330	
R111	RB0348T	100	
R112	RB0404T	22K	
R113	RB0364T	470	
R114	RB0418T	82K	
R116	RB0416T	68K	
R117	RB0390T	5.6K	
R118	RB0380T	2.2K	
R119	RB0356T	220	
R120	RB0400T	15K	
R121	RB0396T	10K	
R122	RB0380T	2.2K	
R123	RB0356T	220	

SYMBOL NO.	STOCK NO.	DESCRIPTION	REMARK
R124	RB0388T	4.7K	
R125	RB0368T	680	
R126	RB0430T	270K	
R127	RB0412T	47K	
R128	RB0400T	15K	
R131	RB0412T	47K	
R132	RB0396T	10K	
R133	RB0408T	33K	
R134	RB0420T	100K	
R135	RB0384T	3.3K	
R136	RB0400T	15K	
R137	RB0372T	1K	
R138	RB0374T	1.2K	
R139A	RB0412T	47K	
R139B	RB0412T	47K	
R140A	RB0404T	22K	
R140B	RB0404T	22K	
R141A	RB0390T	3.3K	
R141B	RB0390T	5.6K	
R142A	RB0372T	1K	
R142B	RB0372T	1K	
R143A	RB0374T	1.2K	
R143B	RB0374T	1.2K	
R144A	RB0388T	4.7K	
R144B	RB0388T	4.7K	
R145A	RB0356T	220	
R145B	RB0356T	220	
R146	RB0348T	100	
R147	RB0396T	10K	
R148	RB0412T	47K	
R149	RB0412T	47K	
R150	RS3069	82 1W Rf	
R151	RB0412T	47K	
R152	RB0420T	100K	
R153	RB0394T	8.2K	
R154	RS2953L	180	
R155	RB0372T	1K	
R156	RB0384T	3.3K	
R161	RK7001	100K, Network	
R162	RB0388T	4.7K	
R163	RB0400T	15K	
R164	RB0388T	4.7K	
R165	RB0372T	1K	
R166	RB0452T	2.2M	
R167	RB0372T	1K	
R169	RB0396T	10K	
R170	RB0404T	22K	
R171	RB0412T	47K	
R172	RB0408T	33K	
R173	RB0408T	33K	
R174	RB0408T	33K	
R175	RB0408T	33K	
R176	RB0412T	47K	
R177	RB0412T	47K	
R178	RB0412T	47K	
R179	RB0412T	47K	
R180	RB0412T	47K	
R181	RB0420T	100K	
R182	RB0420T	100K	
R183	RB0420T	100K	
R184	RB0420T	100K	

SYMBOL NO.	STOCK NO.	DESCRIPTION	REMARK
R185	RB0420T	100K	
R186	RB0412T	47K	
R187	RB0412T	47K	
R189	RB0412T	47K	
R190	RB0412T	47K	
R191	RB0412T	47K	
R192	RB0420T	100K	
R193	RB0420T	100K	
R194	RB0420T	100K	
R195	RB0356T	220	
R196	RB0356T	220	
R201	RB0372T	1K	
R202	RB0432T	330K	
R203	RB0384T	3.3K	
R204	RB0420T	100K	
R205	RB0382T	2.7K	
R206	RB0436	470K	
R207	PB0384T	3.3K	
R208	RB0412T	47K	
R209	RB0420T	100K	
R210	RB0408T	33K	
R211	RB0408T	33K	
R221	RB0342T	56	
R222	RB0380T	2.2K	
R223	RB0348T	100	
R224	RB0348T	100	
R225	RB0372T	1K	
R226	RB0420T	100K	
R227	RB0420T	100K	
R228	RB0396T	10K	
R229	RB0396T	10K	
R230	RB0396T	10K	
R231	RB0430T	270K	
R232	RB0406T	27K	
R233	RB0358T	270	
R234	RB0388T	4.7K	
R235	RB0348T	100	
R236	RB0364T	470	
R237	RB0380T	2.2K	
R238	RB0396T	10K	
R239	RB0382T	2.7K	
R240	RB0400T	15K	
R241	RB0404T	22K	
R242	RB0412T	4.7K	
R243	RB0348T	100	
R601A	RB0416T	68K	
R601B	RB0416T	68K	
R602A	RB0384T	3.3K	
R602B	RB0384T	3.3K	
R603A	RB0428T	220K	
R603B	RB0428T	220K	
R604A	RB0360T	330	
R604B	RB0360T	330	
R605A	RB0428T	220K	
R605B	RB0428T	220K	
R606A	RB0402T	18K	
R606B	RB0402T	18K	
R607A	RB0364T	470	
R607B	RB0364T	470	
R608A	RB0372T	1K	
R608B	RB0372T	1K	

PB-1381

SYMBOL NO.	STOCK NO.	DESCRIPTION	REMARK
R610 R611	RS2522L RS2520L	680 1/2W Rf 470 1/2W Rf	
[Switch]			
SW601 SW602 SW101 SW102	SP0200 SP0200 SS0142 SS0012	SUL232A SUL232A SSR2640 2D SW343-1	EZ, EK
[Trimmer capacitor]			
TC201 TC202	CT0011 CT0011	TZ03R200, 3.2PF TZ03R200, 3.2PF	
[Coil]			
T101 T102 T103	LA1457 LA1209 LA1209	FM trans former Low pass filter Low pass filter	
[Terminal]			
T104 T601 T602 T603	AT0139 AT0140 AT0142 AT0140 AT0140	ANT. RCA, 4P 2P RCA, 4P RCA, 4P	SD
[Trimming potentiometer, crystal]			
VR101 VR102 VR103 VR104 VR201 X101	RT0052 RT0086 RT0025 RT0087 RT0055 TX5004	20K (B) 10K (B) 4.7K (B) 200K 1K (B) Crystal, 4.5MHz	

SYMBOL NO.	STOCK NO.	DESCRIPTION	REMARK
[Capacitor]			
C301 C302	CE1753 CE1717	4.7μ 50V 10μ 16V	
[Diode, IC]			
D301 D302 D303 D304 D305 D306 D307 D308 Q301	TD0231 TD0231 TD0231 TD0231 TD0231 TD0231 TD0230 TD0231 TC0196	LED AR2222S-B1 LED AR2222S-B1 LED AR2222S-B1 LED AR2222S-B1 LED AR2222S-B1 LED AR2222S-B1 LED PG2222SY-B1 LED AR2222S-B1 IC BA6125	
[Resistor]			
R301 R302 R303	RB0362T RB0404T RB0396T	390 22K 10K	

PB-1381

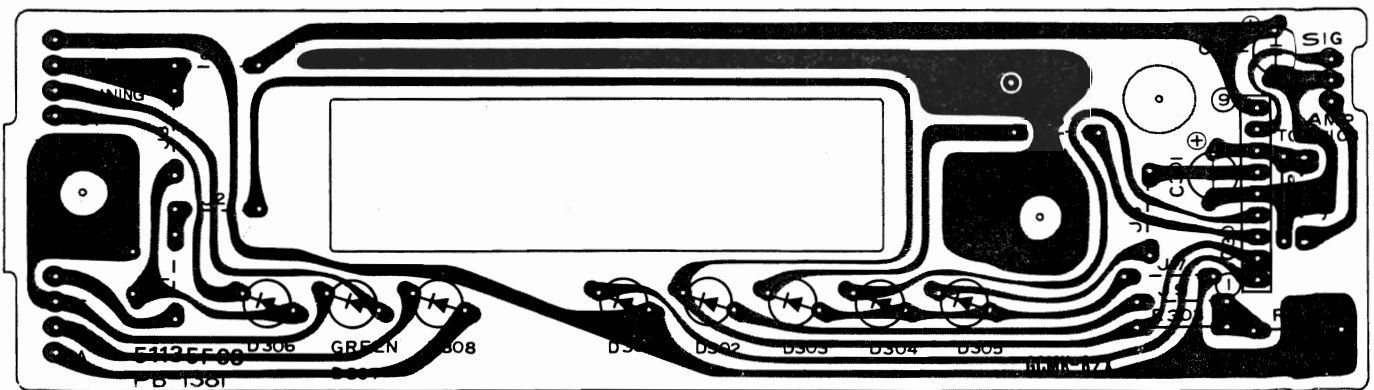

PB-1382

SYMBOL NO.	STOCK NO.	DESCRIPTION	REMARK
[Capacitor]			
C401	CE1717T	10 μ 16V El	
C402	CQ0009T	0.047 μ 50V My	
C403	CE1718T	22 μ 16V El	
C404	CE1717T	10 μ 16V El	
C405	CE1750T	1 μ 50V El	
C406	CK0260T	0.022 μ 25V Ce	
C407	CQ1415	390P 50V St	
C408	CQ1415	390P 50V St	
C409	CK0255T	0.001 μ 50V Ce	
C410	CK0157T	0.04 μ 50V Ce	
C411	CK0260T	0.022 μ 25V Ce	
C412	CE1749T	47 μ 50V El	
C413	CE1717T	10 μ 16V El	
C412	CE1749T	47 μ 50V El	
C413	CE1717T	10 μ 16V El	

[Diode, transistor, IC]			
D403	TD0018	Di, 1K188FM-1	
D404	TD0018	Di, 1K188FM-1	
Q401	TC5027	IC TC4016BP	
Q402	TR0354	TR 2SC2021R	
Q403	TR0354	TR 2SC2021R	
Q404	TR0354	TR 2SC2021R	
Q405	TR0356	TR 2SA937R	
Q406	TR0354	TR 2SC2021R	
Q407	TR0356	TR 2SA937R	
Q408	TR0356	TR 2SA937R	
Q409	TR0354	TR 2SC2021R	
Q410	TR0354	TR 2SC2021R	
Q411	TR0354	TR 2SC2021R	

[Resistor]			
R401	RB0396T	10K	
R402	RB0396T	10K	
R403	RB0396T	10K	
R404	TB0356T	220	
R405	RB0384T	3.3K	
R406	RB0420T	100K	
R407	RB0420T	100K	
R408	RB0396T	10K	
R409	RB0412T	47K	
R410	RB0430T	270K	
R411	RB0424T	150K	
R412	RB0396T	10K	
R413	RB0412T	47K	
R414	RB0372T	1K	
R415	RB0404T	22K	
R416	RB0404T	22K	
R417	RB0380T	2.2K	
R418	RB0378T	1.8K	
R419	RB0394T	8.2K	
R420	RB0384T	3.3K	
R421	RB0372T	1K	
R422	RB0420T	100K	
R423	RB0396T	10K	
R424	RB0388T	4.7K	
R425	RB0412T	47K	

SYMBOL NO.	STOCK NO.	DESCRIPTION	REMARK
R426	RB0404T	22K	
R427	RB0412T	47K	
R428	RB0404T	22K	
R429	RB0412T	47K	
R430	RB0404T	22K	
R431	RB0374T	1,2K	
R432	RB0396T	10K	
R433	RB0404T	22K	
R434	RB0396T	10K	
R435	RB0396T	10K	
R437	RB0412T		

[Switch, coil]			
SW401	SP0199	SUN191A	
T401	LA1192	Anti-bardi filter	

PB-1382

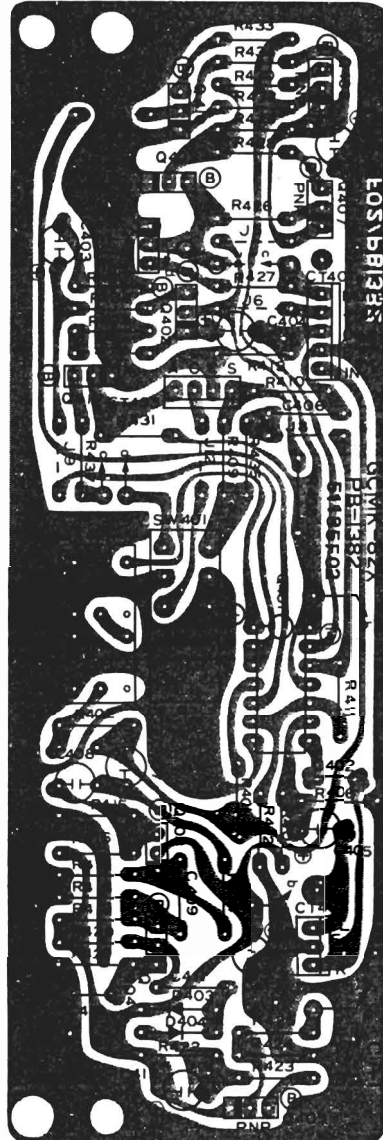

R-5045 AUDIO SECTION

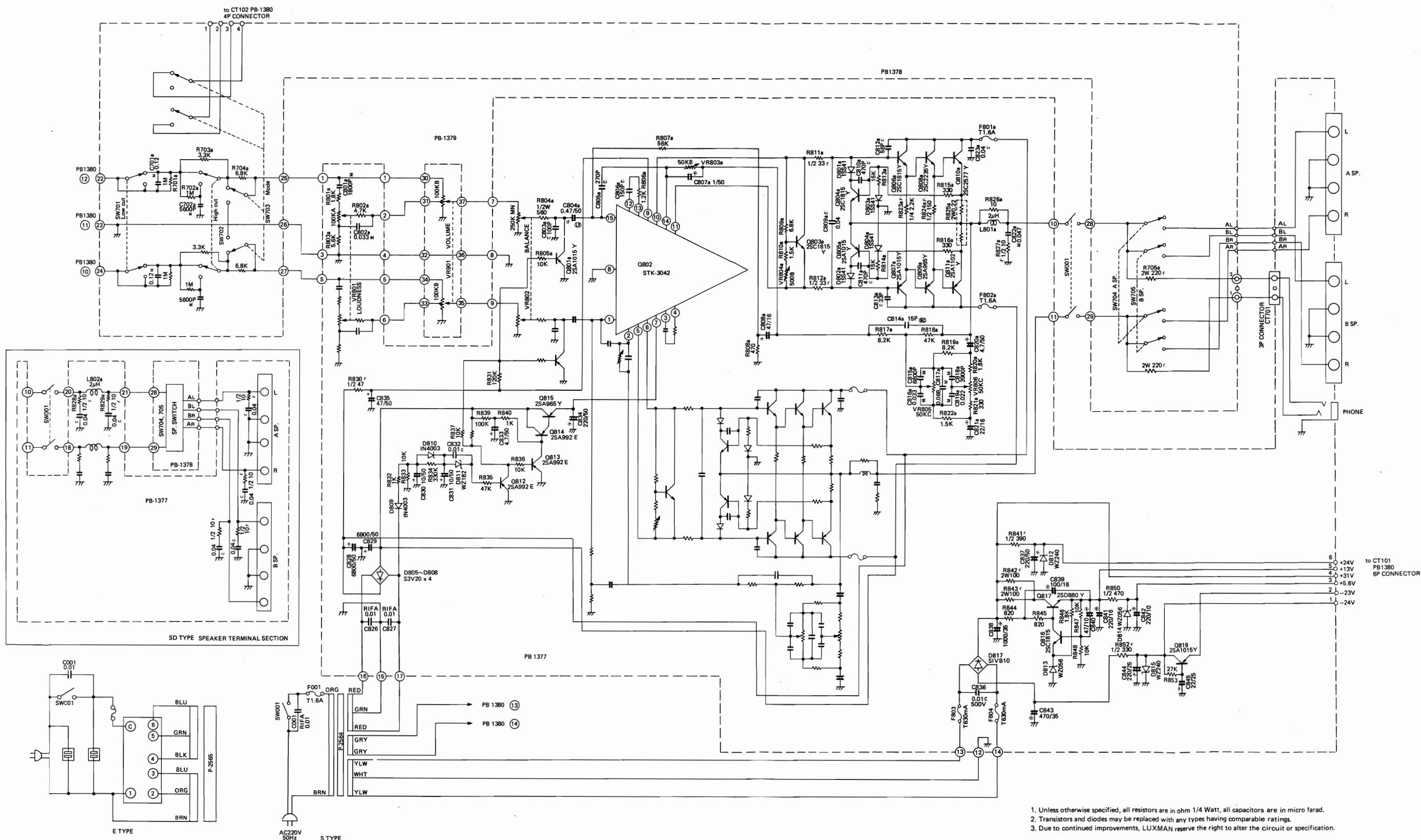

R-5045 AUDIO SECTION

R-5045 RF, EQ SECTION

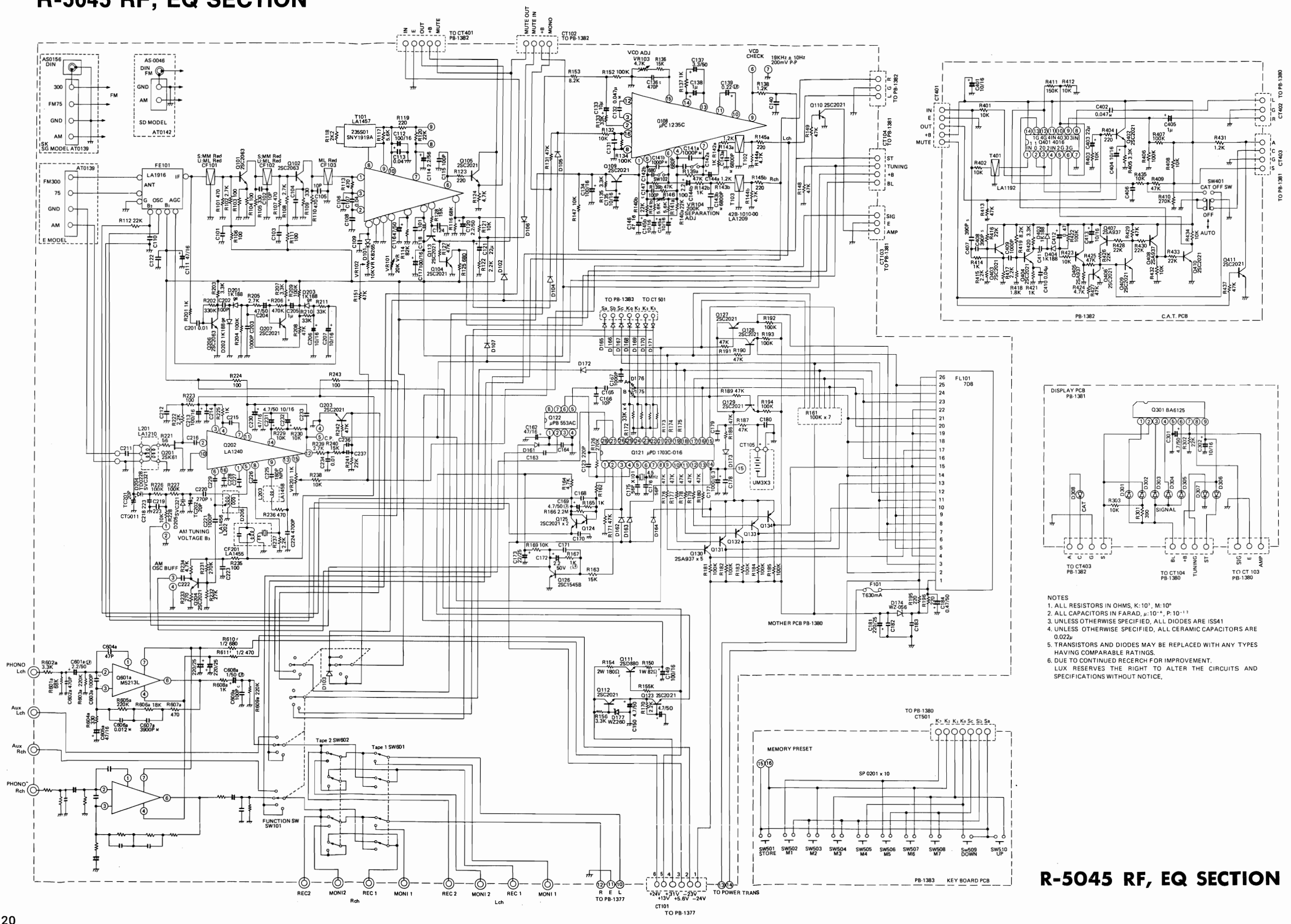

- NOTES
1. ALL RESISTORS IN OHMS, K-10³, M-10⁶
 2. ALL CAPACITORS IN FARAD, μ -10⁻⁶, P-10⁻¹²
 3. UNLESS OTHERWISE SPECIFIED, ALL DIODES ARE ISS41
 4. UNLESS OTHERWISE SPECIFIED, ALL CERAMIC CAPACITORS ARE 0.022 μ
 5. TRANSISTORS AND DIODES MAY BE REPLACED WITH ANY TYPES HAVING COMPARABLE RATINGS.
 6. DUE TO CONTINUED RESEARCH FOR IMPROVEMENT, LUX RESERVES THE RIGHT TO ALTER THE CIRCUITS AND SPECIFICATIONS WITHOUT NOTICE.

R-5045 RF, EQ SECTION

Specification

<FM SECTION> (IEEE/IHF Standard)

	[MONO]	[STEREO]
Usable Sensitivity:	10.3dBf (1.8 μ V)	
50dB Quieting Sensitivity:	15.6dBf (3.3 μ V)	
Signal-to-Noise Ratio at 65dBf:	76dB	
Frequency Response:	30Hz - 15KHz (-1dB)	
Distortion at 65dBf:		
100Hz	0.12%	0.3%
1kHz	0.15%	0.3%
6kHz	0.2%	0.4%
Capture Ratio at 65dBf:	1.4dB	
Adjacent Channel Selectivity:	10dB	
Alternate Channel Selectivity \pm 400kHz:	75dB	
Spurious Response Ratio:	85dB	
IF Response Ratio:	85dB	
Image Response Ratio:	70dB	
AM Suppression Ratio:	56dB	
Stereo Separation:		
100Hz	56dB	40dB
1kHz		45dB
10kHz		39dB
Subcarrier Product Ratio:	62dB	
SCA Rejection Ratio:	60dB	
Muting Threshold:	10 μ V - 300mV (variable)	
Output Level:	800mV	

<AM SECTION>

Usable Sensitivity at 1MHz, 400Hz 30% mod.:	200 μ V/m
Image Response Ratio at 1MHz:	50dB
IF Response Ratio at 1MHz:	40dB
Signal-to-Noise Ratio at 1MHz, 10 m V/m, 400Hz 30% mod.:	50dB
Distortion at 1MHz, 10m V/m, 400Hz/30% mod.:	0.5%

<GENERAL>

Power Consumption:	10W
Dimensions:	438 (W) x 312 (D) x 85 (H) mm (17-1/4" x 12-9/32" x 3-11/32")
Weight:	Net 5kgs (11.0 lbs.) Gross 6kgs (13.2 lbs.)

Specifications and appearance design subject to change without notice.